

Full-Band Capture Cable Digital Tuning

Cable operators are demanding devices that support an increasing number of simultaneous channels, which translates to multiple cable tuners and demodulators in video media server and DOCSIS® 3.0 products in order to provide consumers with new high-bandwidth services, meeting consumer demand for TV everywhere and high-speed Internet throughout the connected home ecosystem. Traditional narrowband analog and wideband cable tuners are limited in their ability to effectively scale the number of channels due to cost, power, and size. Broadcom has introduced a ground-breaking new technology, Full-Band Capture Digital Tuning, that overcomes these limitations and delivers new advantages and features to OEMs, operators, and consumers. Full-Band Capture delivers the cable tuner density and performance that operators need to convert current cable systems to IP-based video platforms.

June 2011



The Challenge

Consumers are demanding TV everywhere and high-speed Internet throughout the home. In response, cable operators are challenged to provide hundreds of HD broadcast channels, thousands of video-on-demand (VOD) programs, and multimegabit high bandwidth services. Content, whether in the home, live broadcast, stored on a digital video recorder (DVR), or other Internet-based system, must be streamed to a variety of devices including digital television (DTVs), mobile devices, tablets, and PCs. Cable DVRs, DOCSIS 3.0 Modems, and Video Media Servers are requiring a dramatically increased number of tuners and demodulators to provide all these simultaneous services. There is a need to create a more efficient distribution of broadcast video streams and IP services to connected devices in the home ecosystem. At the same time, power, size, and cost must be minimized to meet the demands of consumers and accelerate the transition to hybrid IP-based cable platforms that will more efficiently bring additional video streams and IP services to connected devices in the home ecosystem.

Traditional analog tuner architectures do not effectively scale to support receiving four or more channels. To support the simultaneous access of four channels, a system must include four analog tuners and four demodulators. Since analog tuners consume the largest amount power in the RF front end, the overall system power increases and the footprint for four RF tuners account for considerable board size and increased costs.

Wideband tuners have provided some improvements for DOCSIS 3.0 modems, allowing a single analog tuner to access up to a 100 MHz range and then demodulate up to eight channels within the 100 MHz range. While this does reduce the number of analog tuners, it places tight limitations on the frequency allocation of the DOCSIS 3.0 services and cannot be used for broadcast video services. Broadcast video services are typically located anywhere in the 1 GHz cable spectrum. A wideband system with broadcast video would still need four independent wideband tuners to access four channels located anywhere in spectrum.

Cable spectrum is not a greenfield 1 GHz band. There are often factors that limit the full usage of this spectrum such as legacy analog broadcasts, limitations on certain usable frequencies, and legacy boxes that cannot access all ranges. These limitations curtail usable frequencies for new value-added services such as broadband, VOD, and additional digital broadcast channels. Operators prefer to have both DOCSIS and broadcast services located anywhere in their spectrum without constraints for adjacent channels so they can optimally load balance various services and provide consumers with the maximum number of services.

The Solution

Full-Band Capture Digital Tuning is a revolutionary change to the cable front-end architecture to meet the challenging demands of operators, consumers, and hardware vendors while providing efficient scalability for future development. Full-Band Capture reduces cost, saves power and board size to transition current cable platforms to hybrid IP-based solutions, proliferating IP content delivery and services throughout the home and to connected devices.

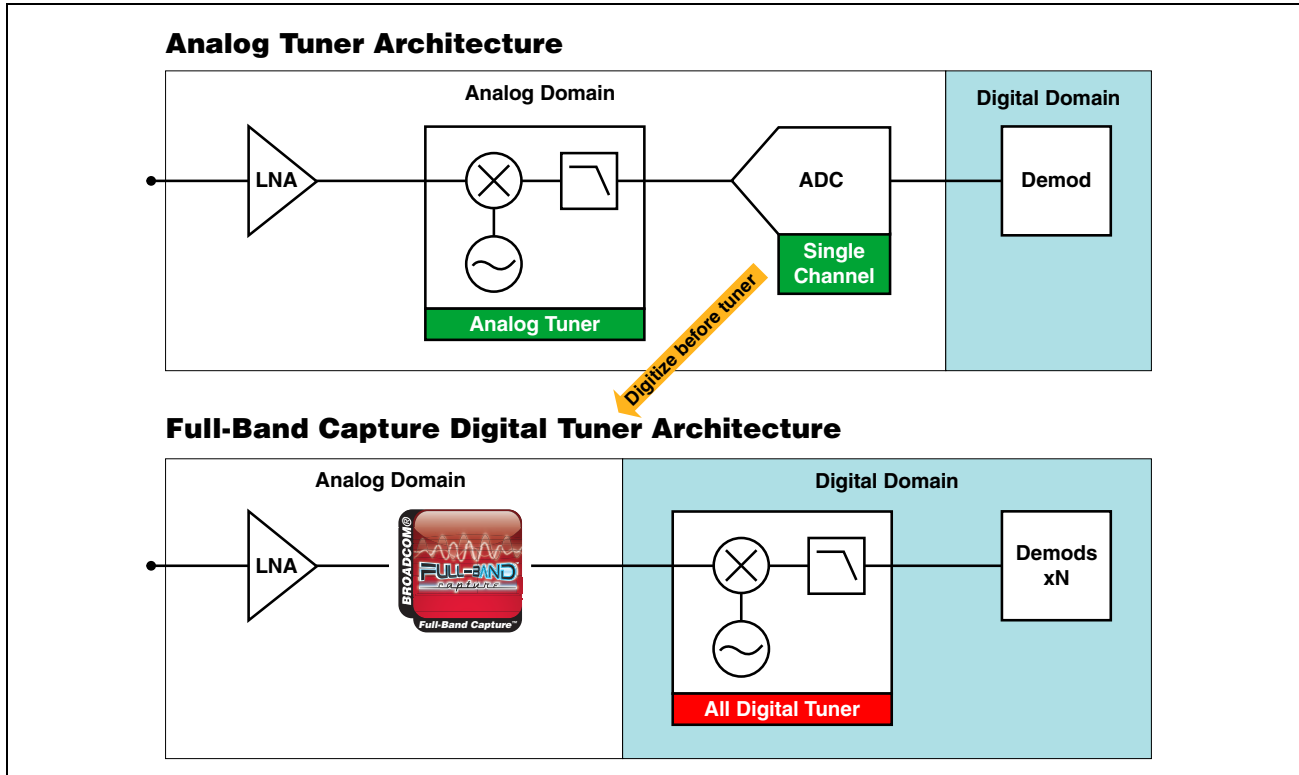

Figure 1: Analog Tuning-to-Full-Band Capture Digital Tuning Comparison

The efficiency of Full-Band Capture converts the entire analog 1 GHz cable signal to a digital signal. This high-speed precision conversion replaces all the analog tuners in a system. With the entire RF signal in digital form, advanced digital signal processing techniques can be used to digitally tune multiple channels simultaneously at near instantaneous speeds. Each digitally tuned channel then feeds the signal into a digital demodulator that outputs a transport stream for use in DOCSIS or broadcast services. One Full-Band Capture Digital Tuner can service any number of demodulators. Each demodulator can access any frequency without restriction or relationship to other channels.

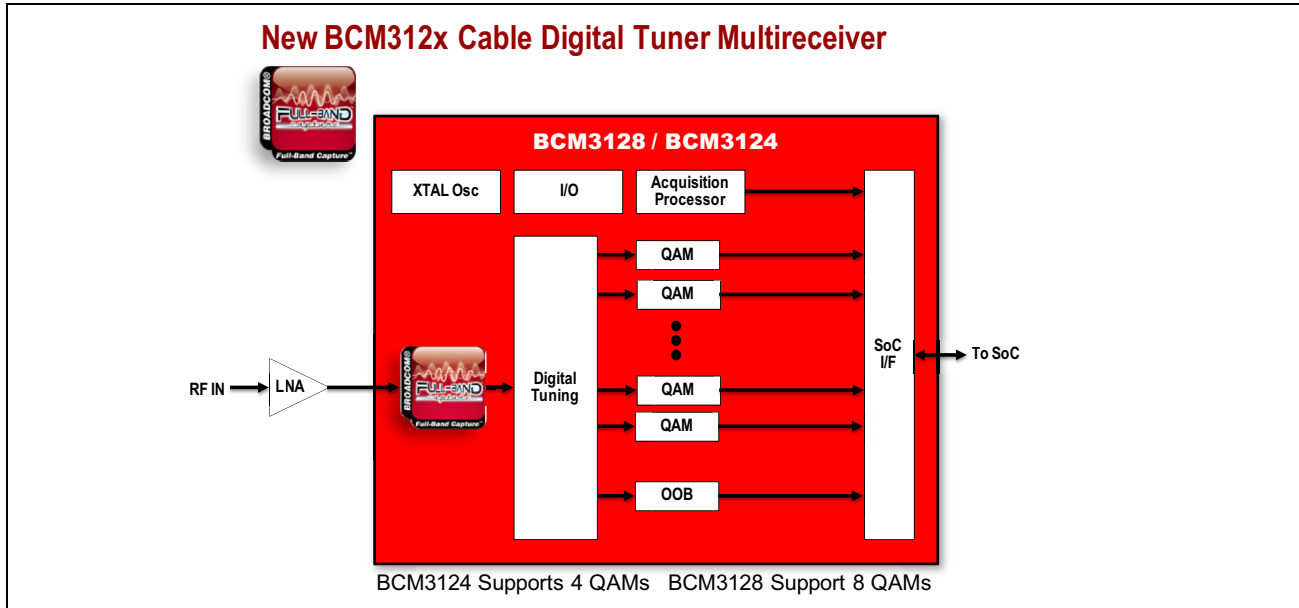

Figure 2: Full-Band Capture Digital Tuner Multireceiver SoC

The BCM312X and BCM3383 are Broadcom’s first Full-Band Capture products to integrate a Full-Band Capture Digital Tuner with eight quadrature amplitude modulation (QAM) demodulators and one Out-of-Band (OOB) Receiver. The BCM3124 integrates a Full-Band Capture Digital Tuner with four QAM demodulators. By using a mainstream 40 nm digital CMOS process, the cable front-end power, size, and cost are significantly reduced. Full-Band Capture Digital Tuning can be integrated in highly complex System-on-a-Chip (SoC) devices for various market segments.

Benefits to OEMs

OEMs realize immediate system component cost savings using Full-Band Capture Digital Receivers: up to nine analog tuners’ chips can be replaced in a gateway system design. The challenges of buffering RF signals to each analog tuner, providing clean power supplies, buffering clock sources, and implementing redundant filters are greatly simplified with the single-chip multireceivers. A single small 10 mm x 10 mm device with a single clock, and minimal passives simplifies board design and reduces the overall size of the system. This in turn significantly reduces the cable front-end system costs.

Full-Band Capture Digital Tuner multireceivers exceed the challenging SCTE-40+ and DVB-C performance requirements demanded by worldwide service providers. Digital tuning allows for new enhanced signal processing techniques that were previously not feasible with analog tuners. Advances in analog-to-digital conversion allow for unprecedented speed and precision.

Additionally, with the removal of the power-hungry analog cable tuners, overall system power is reduced enabling small, attractive form factors. Reduced power enables green products and allows systems to meet current and future energy consumption standards like Energy Star® and the European Code of Conduct.

Benefits to Operators

Operators benefit from Full-Band Capture Digital Tuning with total bandwidth deployment flexibility. Any frequency can be assigned to a given service removing the block tuner restrictions with wideband tuners. For example, there is no longer a requirement for operators to allocate adjacent frequency blocks for DOCSIS® 3.0 services. Each demodulator in a Full-Band Capture system can tune to an entirely different frequency in the 1 GHz band without constraint. So, previously unusable frequencies can now be applied for additional broadband services. Additionally, each demodulator can be allocated to either broadband or broadcast services, and the allocation can be changed over time. This allows operators to seamlessly transition services from broadcast to IP.

Since Full-Band Capture scales easily in systems, operators can confidently design services that use increasing numbers of channels with 8, 16, or even 32 active channels at time.

Benefits to Consumers

Consumers see the end benefit of Full-Band Capture-enabled products. With OEM and operators offering systems with increasing numbers of QAM demodulators and fully flexible frequency selection, consumers can enjoy additional broadband bandwidth, new IP video services, and more HD broadcast and VOD services.

Broadcom's FastRTV™ fast-channel change accelerates channel zapping across frequencies. Customers can quickly surf through many channels with near instantaneous channel change times due to digital tuning, multiple QAM demodulators, and FastRTV acceleration.

Summary

Full-Band Capture Digital Tuning is a revolutionary change to cable front-end architecture. It overcomes the key limitations for scaling analog narrowband and wideband cable tuners:

- Broadcom's Full-Band Capture Digital Tuning technology replaces multiple analog narrowband and wideband video tuners with one SoC for a simpler, smaller, faster, and lower power designs.
- Broadcom's FBC technology enables unprecedented bandwidth scalability and flexibility to more efficiently deploy multituner hybrid set-top boxes and DOCSIS 3.0 cable modem gateways.
- FBC technology accelerates the deployment of IP-based home networks and multiple broadcast video streams throughout the home and beyond providing OEMs, operators, and consumers with smaller and lower power devices.
- Broadcom's 40 nm 8-QAM BCM3128, 4-QAM BCM3124 cable multireceiver SoCs and BCM3383 DOCSIS 3.0 cable gateway SoC are the industry's first fully integrated solutions to support Full-Band Capture technology and are now shipping to customers.

Broadcom® Corporation reserves the right to make changes without further notice to any products or data herein to improve reliability, function, or design.

Information furnished by Broadcom Corporation is believed to be accurate and reliable. However, Broadcom Corporation does not assume any liability arising out of the application or use of this information, nor the application or use of any product or circuit described herein, neither does it convey any license under its patent rights nor the rights of others.

Connecting
everything®



BROADCOM CORPORATION

5300 California Avenue

Irvine, CA 92617

© 2011 by BROADCOM CORPORATION. All rights reserved.

Phone: 949-926-5000

Fax: 949-926-5203

E-mail: info@broadcom.com

Web: www.broadcom.com