

Multi-PHY ICs take home networking to the next level

Combining wired and wireless finally connects the whole home

BY MICHAEL WILSON

Gigle Networks, Redwood City, CA

<http://www.giglenetworks.com>

It's no longer enough for home networks to simply connect PCs, peripherals, and consumer electronics devices for simple file and device sharing. Users want to access the network anywhere in the home, which can only be done by combining both wired (power-line, coaxial-cable, or phone-line) and wireless technologies for optimal coverage.

Users also want to access multiple streams of HD video and other entertainment content over their networks, which means they need sustained high bandwidth with low-latency QoS. And, they also want the easiest possible out-of-the-box experience with simple installation, flexible upgrades, and an network that's easy to manage.

To achieve these objectives, you need networks capable of supporting multiple-physical-layer (multiPHY) switching for both Wi-Fi and wireline. These networks must be able to deliver a high-quality, jitter-free, low-latency user experience for a wide range of content delivery, whether from an STB attached directly to a TV, or a DVR that is located on the other side of the house.

Balancing coverage with quality is one of the biggest challenges to resolve. Wireless technology provides ubiquity and mobility, but at the price of inferior QoS. Wireline technologies offer the necessary QoS for video applications, but few users have access to CAT-5 or coax cable everywhere they want to use their networked devices. And while power line offers another, more accessible, wired option, it requires sophisticated signal-processing algorithms. Multiple wired and wireless options, used together, provide significantly better network performance. In fact, no single networking medium is capable of simultaneously meeting peak bandwidth and QoS requirements across every possible service or application, everywhere in the home.

QoS is becoming increasingly important, especially as over-the-top (OTT) carriers challenge the traditional dominance of telecommunications operators in the home with a new generation of video and other broadband content and services via IP over broadband networks. And 3D content raises additional requirements. In addition to QoS issues, service providers must consider support requirements.

Traditionally, operators simply would not support a service call that revolved around network connectivity; however, as Wi-Fi technology has evolved and matured, carriers began recognizing the need to support a subscriber's home network. This did not pose a major problem until consumers began demanding video streaming and other high-bandwidth applications. Today,

there is a wide variety of transformational OTT video service offerings including Hulu, Netflix, Cinema Now, and other video-delivery platforms and brands.

Meeting subscriber demand for coverage and QoS in a network that is easy for carriers to support requires much more than dual-function extender devices that, as an example, use power-line communications (PLC) to bridge two Wi-Fi zones. The answer is true, hybrid smart-pipe solutions that are capable of both intelligently partitioning traffic streams while combining multiple mediums into larger, higher-bandwidth network pipelines.

One of the most attractive hybrid smart pipes is one that combines Wi-Fi and PLC (see Fig. 1). PLC can be used at any power outlet and can operate in multiphase, 50- or 60-Hz, 110- or 220-V environments. PLC combined with Wi-Fi give significantly better coverage, performance, fault tolerance, and overall noise immunity.

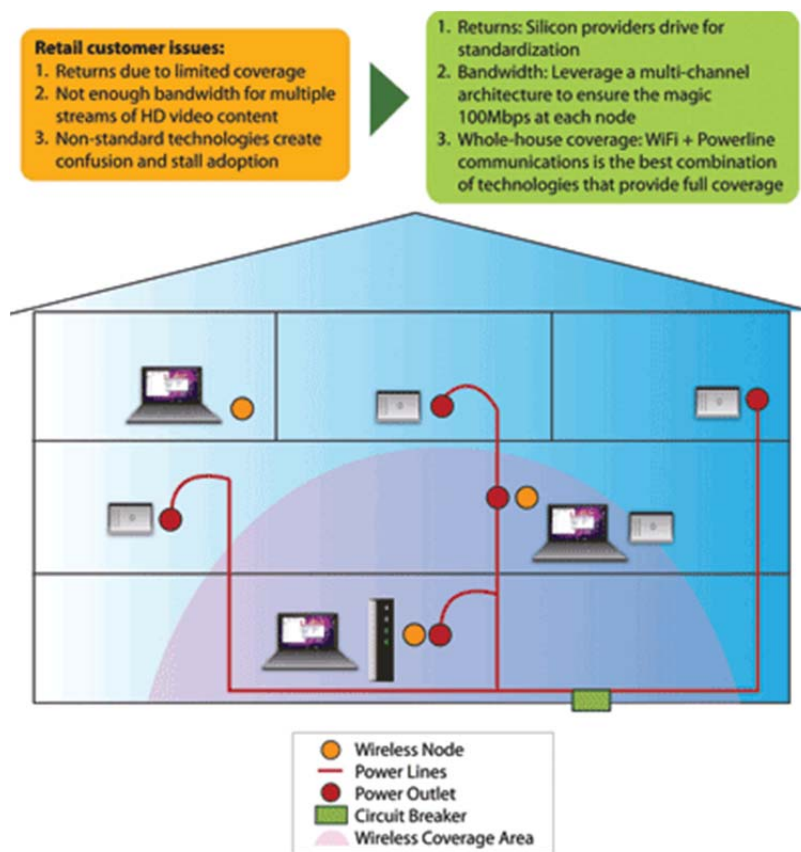

Fig. 1. The connected home: Combining Wi-Fi and power-line communications.

To create a hybrid smart pipe, there must be a switch between the multiple PHY technologies for the interface to the CAT-5, coax, power-line, twisted-pair, or Wi-Fi medium. This switch must include intelligent algorithms to monitor line conditions and channel capacity and allocate traffic streams based on requirements and QoS.

If the status in one medium deteriorates for any reason, the network can reallocate traffic streams. Additionally, the switch can bond individual channels on each medium to deliver one super channel that can support higher throughput rates, more rigorous quality requirements, and broader coverage.

System designers have many options for delivering these hybrid smart pipes. There are two well established standards in coax home networking. The Multimedia over Coax Alliance's (MoCA) standard has been deployed by Verizon and other carriers, and the HomePNA Alliance's HPNA technology has been deployed by AT&T. Each standard operates in different domains and on different mediums, so while they don't interoperate, neither do they interfere with each other.

The other wireline option is PLC home networking. One of PLC technology's benefits is its ability to leverage HomePlug interoperability specifications to provide networking without the need for running new cables, configuring software, or even understanding networking technology. To create a point-to-point connection, the user simply plugs the PLC-enabled devices and the network is instantly formed.

PLC also is now supported by the first global PLC standard, IEEE standard 1901. Backed by the HomePlug Powerline Alliance and Panasonic, IEEE 1901 is quickly becoming the de-facto standard, and includes a coexistence protocol called ISP (intersystem protocol) which is designed to ensure that existing and future technologies that share the medium won't interfere with each other. The IEEE 1901 standard, when published, is expected to lead to the widespread adoption of PLC network interface connections inside a broad range of consumer electronics devices.

The standard also addresses applications such as smart grid/smart energy, and there is the opportunity to create, for example, an entertainment device inside a home gateway that can communicate with an energy-management device in a heater control (see Fig. 2). To this end, there is HomePlug GP (Green PHY), the low-power/bandwidth/cost solution for energy management, automation, and plug-in electric vehicle applications, for which products will be available later this year.

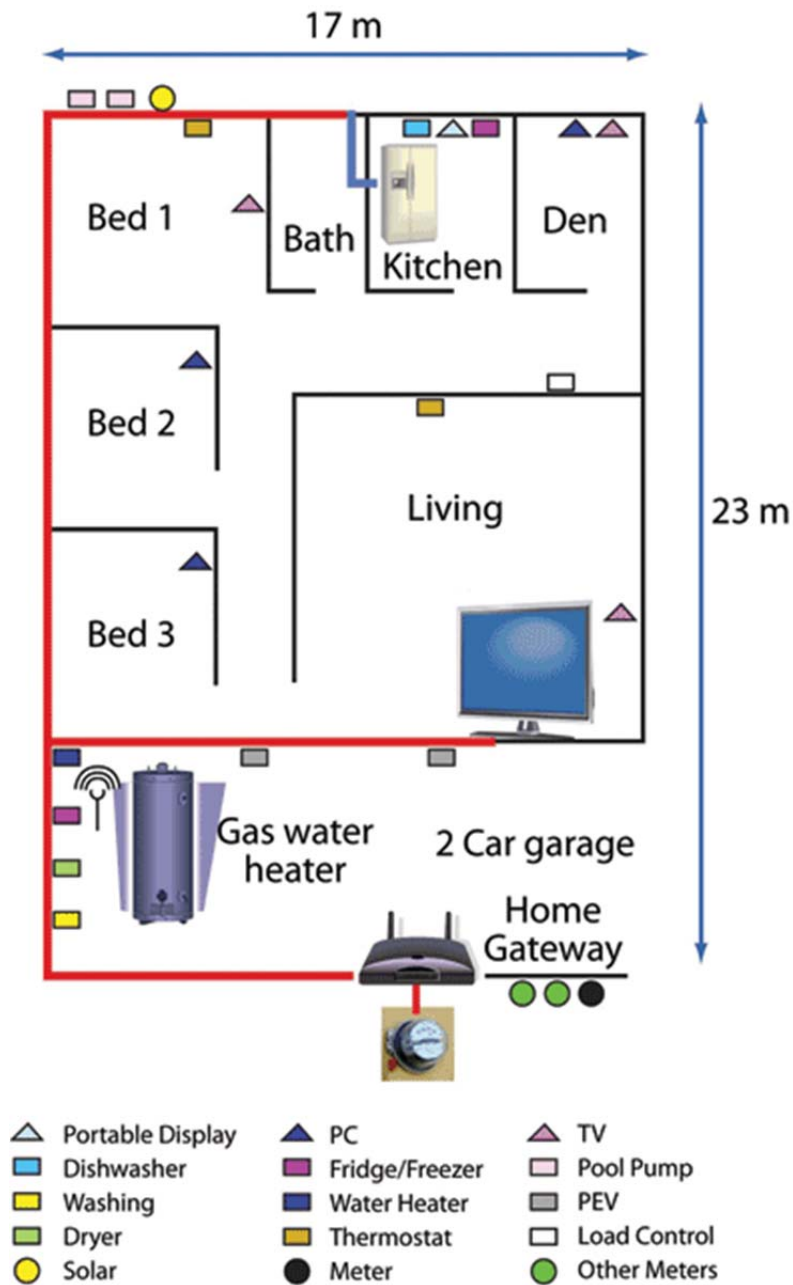

Fig. 2. Power-line communication (PLC) as part of home smart energy network.

There also is HomePlug AV2, an advancement of the current HPAV standard and a solution for even greater capacity to deliver multiple streams of HD content and additional services relying on a strong, robust and deterministic home network (the specification will be completed in early 2011).

To connect mobile and unpowered fixed-location devices (such as window sensors) into next-generation entertainment/automation networks, we expand intelligent switching capabilities to

include other connection methods such as ZigBee, Zwave, and Wi-Fi, to facilitate intrasphere communication and interoperability.

One example of multiPHY technology taking the first steps in this direction is Gigle Networks' GGL541 Gigabit and GGL301 200-MHz intelligent multiPHY switch ICs, which are certified HomeplugAV compliant and now support IEEE 1901's Inter System Coexistence Protocol. They enable home-networking devices to deliver wireline Gigabit performance by operating over any combination of power-line, phone-line, and coaxial cable mediums (see Fig. 3).

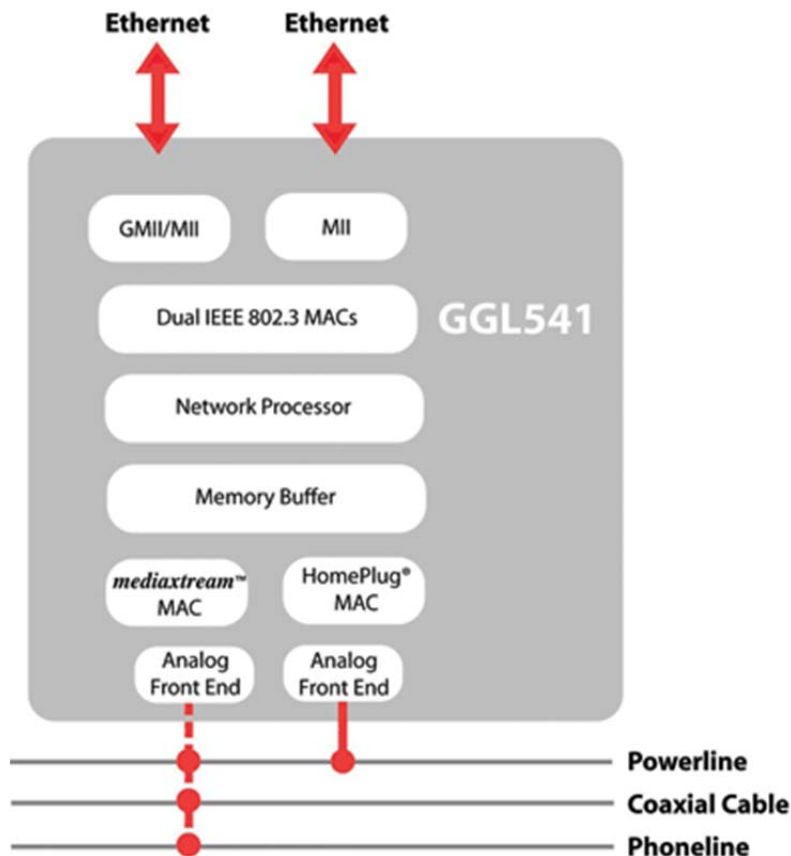

Fig. 3. Gigle Networks' Mediapstream technology block diagram.

These ICs can be combined with Gigle's Xtendnet technology to aggregate traffic from one or more of these channels, improving coverage, bandwidth, and QoS. Xtendnet is able to work in concert with Wi-Fi to allow IP streams to be intelligently managed across any of the wireline transports, while aggregating the traffic with a Wi-Fi stream. Together, Mediapstream and Xtendnet technologies have the ability to deliver high-definition content to 99% of power outlets in a typical home. ■